

KOMATSU®

GD535-5

GD
535

HORSEPOWER

Gross: 115 kW 154 HP / 2000 min⁻¹

Net: 108 kW 145 HP / 2000 min⁻¹

OPERATING WEIGHT

13820 kg

BLADE LENGTH

3.71 m³



Photos may include optional equipment.

WALK-AROUND





PRODUCTIVITY

- ▮ High Productivity & Low Fuel Consumption
- ▮ Lock-up Torque Converter Transmission
- ▮ Long Wheelbase & Short Turning Radius

ECOLOGY & ECONOMY

- ▮ Komatsu Technology
- ▮ High Performance and Low Emission Engine
- ▮ Engine Power Mode Selection System

COMFORT

- ▮ Excellent Visibility
- ▮ ROPS/FOPS Canopy (ISO 3471/ISO 3449)

MAINTENANCE

- ▮ Easy Maintenance Design
- ▮ Maintenance Information Display

RELIABILITY

- ▮ Components that Prevent Machine Failure and Improve Machine Reliability

ATTACHMENTS

- ▮ Komatsu genuine attachment tools

* Information and Communication Technology

ICT* & KOMTRAX

- ▮ High Resolution 3.5" Liquid Crystal Display (LCD) Color Monitor
- ▮ KOMTRAX

GD535-5	
HORSEPOWER	Gross: 115 kW 154 HP / 2000 min ⁻¹ Net: 108 kW 145 HP / 2000 min ⁻¹
OPERATING WEIGHT	13820 kg
BLADE LENGTH	3.71 m

PRODUCTIVITY

High Productivity & Low Fuel Consumption

Improvements in transmission and axles raises efficiency, and the sophisticated electronic engine and transmission control offers optimized output - all combined - realizing 15% better production and 14% better fuel consumption in the field compared with the GD511A-1.

Production

15% up (P mode)

Fuel consumption

14% reduction (E mode)

(Compared with GD511A-1)

*Fuel consumption varies depending on the job conditions.



Lock-up Torque Converter Transmission

The lock-up torque converter transmission is specially designed for Komatsu graders. This provides both efficiency of direct shifting and operability of automatic shifting.

1) Transmission mode selection

• Auto mode

Torque converter allows the operator to be free from inching pedal operation and provides smooth machine control and much torque when starting, which allows the operator to start from even 4th gear. Besides, automatic gear shifting in F4-F8 gears provides high maneuverability.

• Manual mode

Transmission drives directly in all gears, works the same way as conventional power shift machine with constant machine speed and economical operation.

Even in manual mode, torque converter works in shift changing to minimize shift shock.



2) Engine stall prevention function

The combination of manual mode and auto mode avoids engine stalling which leads to smooth operation in low speed.

3) Electronic over-speed protection

Helps to prevent engine and transmission damage due to premature downshifting and grade-induced overspeeding.

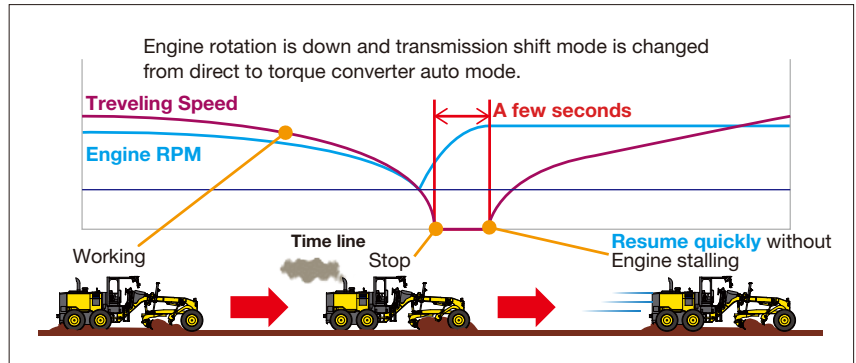

Longest Wheelbase & Short Turning Radius

The longest wheelbase ensures superior grading ability. Wide steering and articulation angle keeps short turning radius, for excellent maneuverability.



ECOLOGY & ECONOMY

Komatsu Technology

Komatsu uniquely develops all major components including total control system, like engines, electronics, and hydraulic components. With this “Komatsu Technology” and continuous customer feedback, Komatsu has been achieving great advancements in technology. This resulted in new generation of high performance and environmentally friendly products.

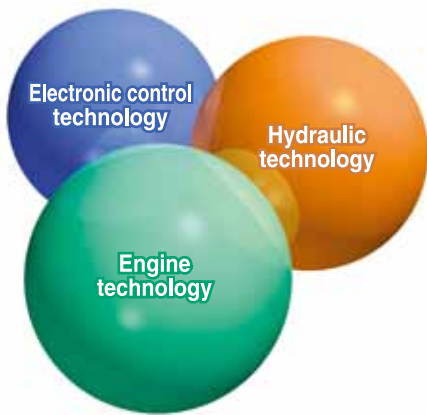

High Performance and Low Emission Engine

Komatsu SAA6D107E-1, turbocharged and air-to-air aftercooled engine, realizes high productivity and low fuel consumption. Common rail injection system provides precise throttle control and thus it delivers higher work speeds with high horsepower. Two P and E modes optimize engine outputs and help to reduce fuel consumption.





Engine Power Mode Selection System

The system allows the operator to select from the two modes, <P mode> or <E mode>, according to the working conditions. The selector switch which is on the console switch is easy to access.



- **P mode**

Maximize production by taking full advantage of engine output. Appropriate for job sites which emphasize productivity.

- **E mode**

Suited for carrying out lighter work economically. This feature provides the sufficient power, better fuel consumption, and prevents tire slipping to extend tire life.



COMFORT

Excellent Visibility

Excellent visibility of hexagonal floor and rear layout side pillar boosts operator's confidence and productivity in all grader applications. Well-positioned blade linkage provides an unobstructed view of the moldboard and front tires.



ROPS/FOPS Canopy

Low profile canopy is designed to ensure ROPS/FOPS (ISO 3471/ISO 3449) certification. The wide view reduces operator's fatigue.



Adjustable Control Console

The control console moves back and forth and the operator easily gets in and out of the canopy. The steering wheel also tilts to suit the operator's preference.



Electric Throttle Control

Throttle is electronically controlled and the operator can set the optimal engine RPM at hand.



Lunch Box Tray

The tray for personal items, placed at the left side of the operator's seat.



MAINTENANCE

Easy Maintenance Design

Ground refueling

Easily refueling from the ground eliminates the need for climbing on and down from the tandem.



Large fuel filter and fuel pre-filter with water separator

Provides the large filter with enhanced filtering performance, surely removes water and dirt in fuel to prevent fuel system troubles.



Fuel pre-filter

Service access platform

The punched metal foot plates on the tandem and grab rails ensure safety maintenance and inspection.



Easy access to service points

Wide-open engine hoods improve accessibility to service points. All major service points are accessible from the ground level.



Maintenance Information Display

“Maintenance time caution lamp” display

When the remaining time before maintenance becomes less than 30 hours*, the maintenance time monitor appears. Pressing the key switches on the monitor to change to the maintenance screen.

* The setting can be changed within the range between 10 and 200 hours.

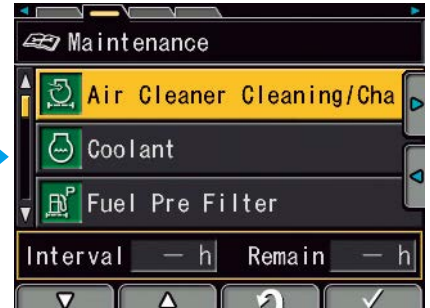

RELIABILITY

Components that Prevent Machine Failure and Improve Machine Reliability

Slip clutch circle drive

Protects the work equipment from shock load when the blade hits an obstruction. Return of the blade position, it is easily done by lever.



Hydraulically controlled wet multiple-disc brake

This brake system is completely sealed and adjustment-free. The large braking surface provides dependable braking capability and extends life before an overhaul.



Sealed connectors

Main harnesses and controller are connected by sealed connectors providing high reliability, water resistance, and dust resistance.

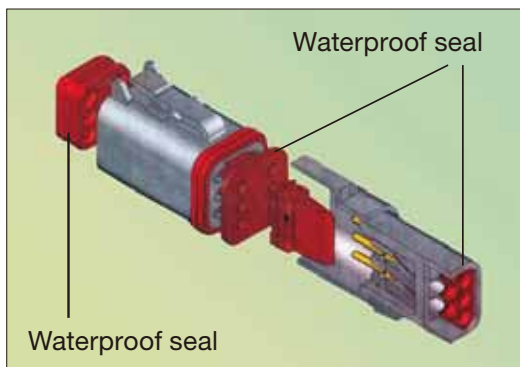

Double seal cylinder (Blade side shift cylinder)

A double-seal design is used for the blade side shift cylinder, which is installed near the ground and possibly gets damage by dirt.

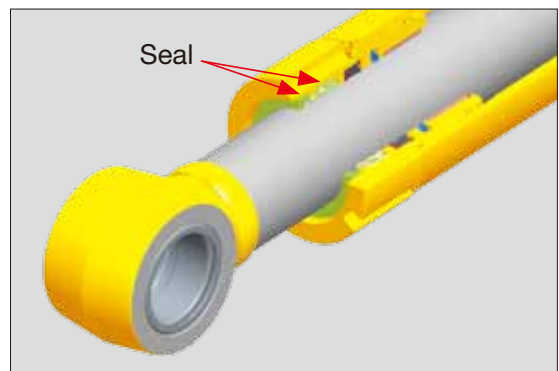

Battery Location

The battery bay is elevated from the ground and prevents intrusion of dusts into the battery and power supply circuit.



ATTACHMENTS

Komatsu Genuine Attachment Tools

Moldboard

Fabricated from high carbon steel.
Includes replaceable metal wear inserts, cutting edge and end bits.
Cutting edge and end bits are hardened.



Scarifier

Digs up hard material cannot be removed by the blade.
This scarifier can accommodate up to 9 teeth.



KOMATSU NEW ENGINE TECHNOLOGIES



High Resolution 3.5" LCD Color Monitor

The high resolution 3.5-inch color LCD monitor improves its visibility. The function switches are simple and easy to operate. The operator easily accesses various user menus like maintenance information, operation, and record, or adjusts the machine settings.

Indicator, switches

- | | |
|---|--------------------------------------|
| 1 LCD unit | 8 Speedometer |
| 2 Warning display | 9 Tachometer |
| 3 Pilot lamp | 10 Articulation indicator |
| 4 Pilot display | 11 Shift indicator |
| 5 Engine coolant temperature gauge | 12 Fuel gauge |
| 6 Torque converter oil temperature gauge | 13 Gear shift lever position display |
| 7 Service meter / Odometer / Clock / Fuel consumption gauge display | 14 Function switches |

Visual user menu

The menus are grouped according to each function with easily understandable icons which enable the operator to reach the information intuitively.

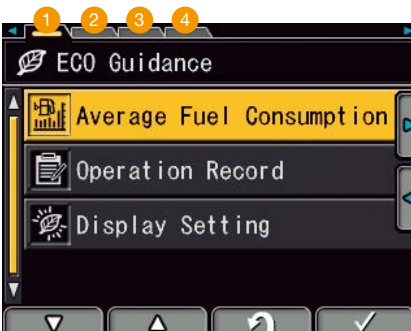

- 1 ECO Guidance
- 2 Maintenance
- 3 Monitor settings
- 4 Message Display

Operation record and fuel consumption history

The energy saving guidance menu enables the operator to check the operation record and fuel consumption history by pushing the button. The records can be used to reduce the overall fuel consumption.



Operation record



Fuel consumption record

Maintenance history

The machine can remember the maintenance history such as changing the engine oil.

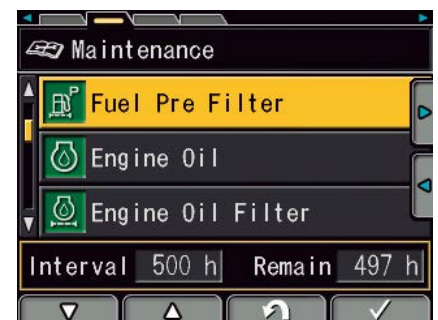



KOMTRAX assists customer's equipment management and contributes to fuel cost cutting

Equipment management support

KOMTRAX terminal installed on your machine collects and sends information such as machine location, working record, machine conditions, etc. using wireless communication. You can review the KOMTRAX data remotely via the online application. KOMTRAX not only gives you the information on your machine, but also the convenience of managing your fleet on the Web.



Machine monitoring



Monthly SMR record

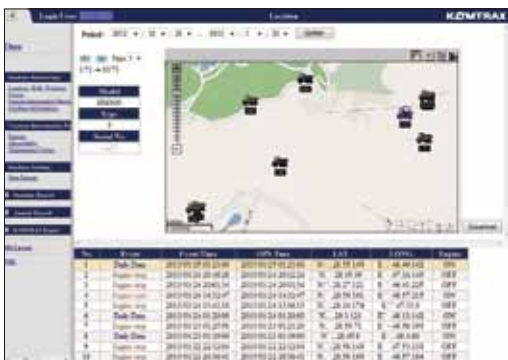

Location

Date	Working Hours	Working Rate	Working Quantity	Fuel	Working Cost
2010/10/24	00:00	00:00	00:00	00:00	00:00
2010/10/23	00:00	00:00	00:00	00:00	00:00
2010/10/22	00:00	00:00	00:00	00:00	00:00
2010/10/21	00:00	00:00	00:00	00:00	00:00
2010/10/20	00:00	00:00	00:00	00:00	00:00
2010/10/19	00:00	00:00	00:00	00:00	00:00
2010/10/18	00:00	00:00	00:00	00:00	00:00
2010/10/17	00:00	00:00	00:00	00:00	00:00
2010/10/16	00:00	00:00	00:00	00:00	00:00

Monthly working record

*KOMTRAX may be unable to be used in some countries or the areas. Please consult your Komatsu distributor.

- Location information / Operational status
- Service Meter
- Engine lock
- Gauge level
- Error / Caution
- Time for replacement
- Load information
- Average gas mileage



KOMATSU TOTAL SUPPORT



Komatsu Total Support

To keep your machine available and minimize operation cost when you need it, Komatsu Distributor is ready to provide variety of support before and after procuring the machine.

Fleet recommendation

Komatsu Distributor can study customer job site and provide the most optimum fleet recommendation with detailed information to meet all of your application needs when you are considering to buy new machines or to replace the existing ones from Komatsu.



Product support

Komatsu Distributor secure the certain quality of machine will be delivered.

Parts availability

Komatsu Distributor is available for emergency inquiry by the customers for genuine, quality guaranteed Komatsu parts.

Technical support

Komatsu product support service (Technical support) are designed to help customer. Komatsu Distributor offers a variety of effective services how much Komatsu is dedicated to the maintenance and support of Komatsu machine.

- Preventive Maintenance (PM) clinic
- Oil & Wear analysis program

Repair & maintenance service

Komatsu Distributor offers quality repair service, periodical maintenance, and maintenance service to the customer, utilizing and promoting Komatsu developed programs.

Komatsu Reman (Remanufactured) components

Komatsu Reman products are the result of the implementation of the Komatsu global Reman policy which establishes and agrees to reduce the owning, operating and total Life Cycle Costs (LCC) to Komatsu's customer through prompt delivery, high quality and competitively priced in own remanufactured products (QDC).



SPECIFICATIONS



ENGINE

ModelKOMATSU SAA6D107E-1
 Type.....Water-cooled, 4-cycle, direct injection
 AspirationTurbocharged and air to air aftercooled
 Number of cylinders6
 Bore.....107 mm
 Stroke124 mm
 Piston displacement 6.69 L
 Horsepower (Manual mode)
 P-mode
 SAE J 1995 Gross 115 kW 154 HP/2000 min⁻¹
 ISO 9249/SAE J 1349 Net 108 kW 145 HP/2000 min⁻¹
 E-mode
 SAE J 1995 Gross 107 kW 143 HP/2000 min⁻¹
 ISO 9249/SAE J 1349 Net 101 kW 135 HP/2000 min⁻¹
 Maximum torque..... 658 Nm 67.1 kgm/1450 min⁻¹
 Torque rise 24 %
 Fan speed Max 1628 min⁻¹
 Air cleaner 2-stage, dry-type
 U.S. EPA Tier 3 and EU Stage 3A emissions equivalent.



TRANSMISSION AND TORQUE CONVERTER

Full power shift transmission with torque converter and lock-up.
 Speeds (at rated engine speed)

Gear	Forward	Reverse
1st	4.2 km/h	4.7 km/h
2nd	5.9 km/h	9.1 km/h
3rd	8.0 km/h	17.8 km/h
4th	11.3 km/h	34.1 km/h
5th	15.7 km/h	-
6th	22.0 km/h	-
7th	30.1 km/h	-
8th	42.0 km/h	-

Maximum travel speed at engine high idle is 46.0 km/h.



TANDEM DRIVE

Oscillating welded box section..... 490 mm x 203 mm
 Side wall thickness: Inner 22 mm
 Outer..... 19 mm
 Wheel axle spacing 1525 mm
 Tandem oscillation 11 ° forward, 13 ° reverse



FRONT AXLE

Type.....Solid bar construction welded steel sections
 Ground clearance at pivot..... 580 mm
 Wheel lean angle, right or left..... 16 °
 Oscillation, total..... 32 °



REAR AXLE

Alloy steel, heat treated, full floating axle with lock/unlock differential.



WHEELS, FRONT AND REAR

Bearings Tapered roller
 Tires..... 13.00-24-12PR, tubeless
 Tire rims (demountable) 9" one-piece rims



STEERING

Hydraulic power steering providing stopped engine steering meeting ISO 5010.
 Minimum turning radius 7.0 m
 Maximum steering range, right or left..... 49 °
 Articulation 25 °



BRAKES

Service brake Foot operated, wet multiple-disc brakes, hydraulically actuated on four tandem wheels.
 Parking brake Manually actuated, spring applied, hydraulically released caliper.



FRAME

Front Frame Structure
 Height 300 mm
 Width 280 mm
 Side 22 mm
 Upper, Lower..... 28 mm



DRAWBAR

A-shaped, welded construction for maximum strength with a replaceable drawbar ball.
 Drawbar frame..... 220 mm x 16 mm



CIRCLE

Single piece rolled ring forging. Six circle support shoes with replaceable wear surface. Circle teeth hardened on front 180° of circle.
 Diameter (outside)..... 1410 mm
 Circle reversing control hydraulic rotation 360 °



MOLDBOARD

Hydraulic power shift fabricated from high carbon steel. Includes replaceable metal wear inserts, cutting edge and end bits. Cutting edge and end bits are hardened.

Dimensions 3710 mm x 645 mm x 16 mm
 Arc radius 329 mm
 Cutting edge 152 mm x 16 mm
 Replaceable/Reversible side edges . . . 229 mm x 496 mm x 13 mm

Blade pull
 Base GVW 7785 kg

Blade down pressure
 Base GVW 6510 kg



BLADE RANGE

Moldboard side shift:

Right 1050 mm
 Left. 970 mm

Maximum shoulder reach outside rear tires (frame straight)

Right 1990 mm
 Left. 1920 mm

Maximum lift above ground 480 mm
 Maximum cutting depth 565 mm
 Maximum blade angle, right or left. 90 °
 Blade tip angle 40 ° forward, 3 ° backward



HYDRAULICS

Hydraulic pumps:

Tandem gear pump for work equipment steering control Capacity 72 L/min + 36 L/min

Relief valve setting:

Work equipment 19.1 MPa 195 kg/cm²
 Steering 17.7 MPa 180 kg/cm²



INSTRUMENT

Electric monitoring system with diagnostics:

Gauges:

Standard articulation, engine coolant temperature, fuel level, speedometer, transmission shift indicator, engine tachometer, torque converter oil temperature

Warning lights/Indicator:

Standard battery charge, brake oil pressure, inching temperature, directional indicator, engine oil pressure, hydraulic oil temperature, heater signal, lift arm lock, parking brake, torque converter oil temperature, eco, P mode, fan reverse, rpm set, high beam, working lights



CAPACITIES (REFILLING)

Fuel tank 271 L
 Cooling system 24 L
 Crank case 23.1 L
 Transmission 45 L
 Final drive 13 L
 Tandem housing (each). 51 L
 Hydraulic system. 51.5 L
 Circle reverse housing. 4.1 L



OPERATING WEIGHT (APPROXIMATE)

Includes lubricants, coolant, full fuel tank, with ROPS/FOPS canopy and scarifier.

Total. 13820 kg
 On rear wheels 4090 kg
 On front wheels. 9730 kg



SCARIFIER (OPTIONAL)

Middle, V-type

Working width 1065mm
 Scarifying depth, maximum 200 mm
 Scarifier shank holders 9
 Scarifier shank holders spacing 130 mm



DIMENSIONS

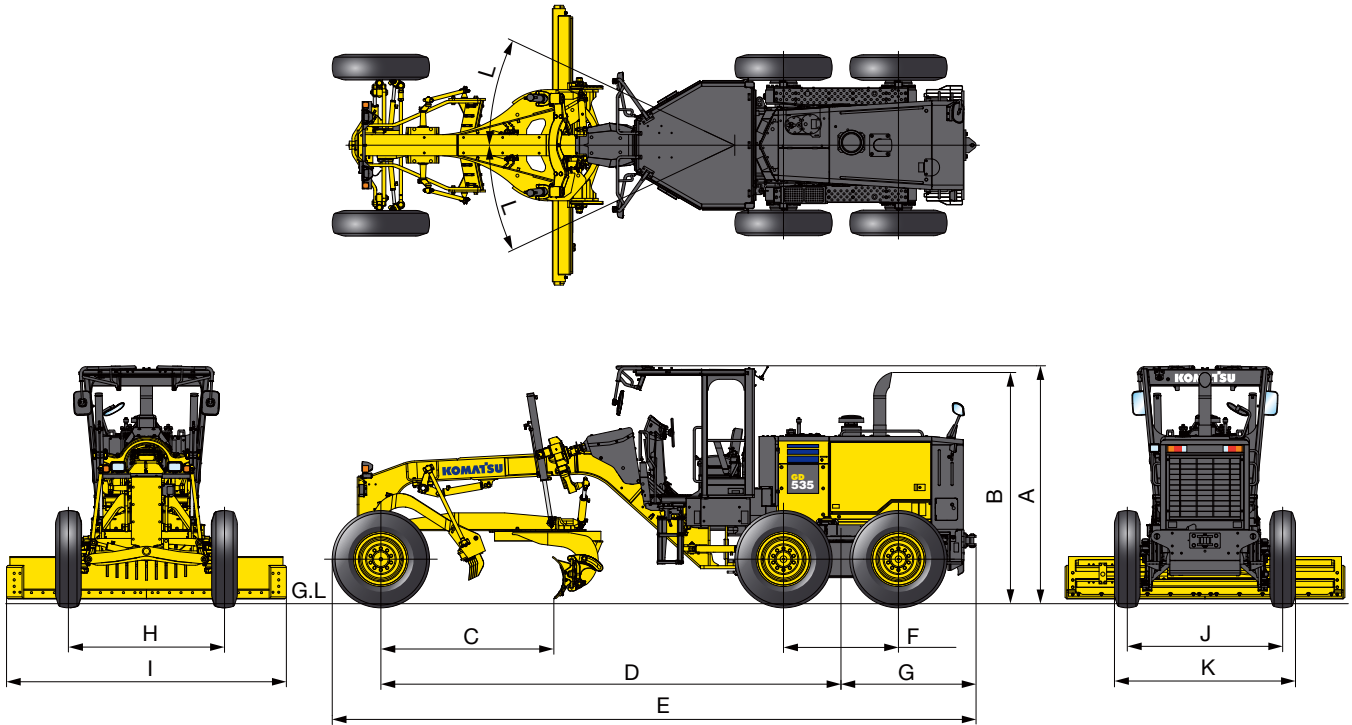

A	Height : Canopy	3145 mm
B	Hight : Muffler	3055 mm
C	Cutting edge to center of front axle	2265 mm
D	Wheelbase to center of tandem	6100 mm
E	Overall length	8540 mm
F	Tandem wheelbase	1525 mm
G	Center of tandem to rear bumper	1795 mm
H	Tread (front)	2070 mm
I	Width of standard moldboard	3710 mm
J	Tread (rear)	2060 mm
K	Width over tires	2425 mm
L	Articulation, left or right	25°



STANDARD EQUIPMENT

Engine and Related Items

- Air intake extension
- Double element air cleaner and dust indicator
- Engine: Komatsu SAA6D107E-1, U.S. EPA Tier 3 and EU Stage 3A emissions equivalent, turbocharged and air-to-air aftercooled, 135HP/145HP net horsepower
- Fuel pre-filter

Electrical Systems

- Alarm, back-up
- Alternator, 24V/35A
- Battery, 2 x 12V/112Ah
- Horn, electric
- Indicators: parking brake, turn signal, lighting, high beam, brake oil pressure
- KOMTRAX, 3G or Orbcomm
- Lights: back-up, stop, tail, directional, headlights (2 halogen type, front bar mounted)
- Multi color monitor

Operator Environment

- Canopy: low profile enclosed ROPS/ FOPS (ISO 3471/ISO 3449)
- Console, adjustable with instrument panel monitoring system
- Floor mat
- Mirrors: right and left exterior mirrors
- Seat, vinyl with seat belt

Power Train

- Axle, rear full floating, planetary type
- Brake, parking, spring applied, hydraulic release, disc type
- Dual mode transmission (F8-R4) power sift, direct drive and torque converter with auto shift, engine stall prevention function
- Service brakes, fully hydraulic wet disc
- Tires and rims: 13.00-24-12PR tubeless bias tires on 9" rims (6)

Work Equipment and Hydraulics

- 8 section hydraulic control valve
- Circle, drawbar mounted, 360° rotation hydraulic blade lift and circle side sift
- Circle slip clutch
- Moldboard: 3710 mm x 645 mm x 16 mm with replaceable end bits, through-hardened cutting edges 152 mm x 16 mm, hydraulic blade side shift
Maximum moldboard angle position 90° right and left
- Steering, full hydraulic with tilt steering wheel plus leaning front wheels and frame articulation w/anti-drift check valves

Other Standard Equipment

- Fuel tank, ground level access
- Painting, Komatsu standard color scheme
- Steps and handrails, rear, right and left side
- Vandalism protection includes lockable access to fuel tank, battery cover and engine side covers
- Work lamps: front (2), rear (1)



OPTIONAL EQUIPMENT

- 9 section hydraulic control valves
- Alternator, 24V/60A
- Differential, lock/unlock
- Fire extinguisher
- General toolkit
- Hydraulic blade tip
- Large capacity batteries, 2 x 12 V/120 Ah
- Licence-plate light
- Pre-cleaner, Turbo II
- Scarifier, 9-shank type
- Steering cylinder guard
- Tires and rims: 14.00-24-12PR tubeless bias tires on 9" rims (6)
- Tool box with lock

KOMATSU[®]